

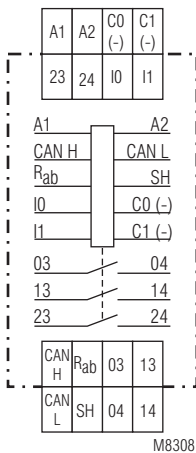

- According to IEC/EN 61 131-2, EN 50 178
- CANopen interface according to DS301 V3.0
  - Complete master function
  - Transfer rate up to 1 Mb/s
- 2 digital inputs for DC 24 V
- 2 relay outputs
- LED indicators
- Standard programming software CoDeSys under Windows according to IEC/EN 61131-3:
  - Instruction set
  - Ladder diagram
  - Function block diagram
  - Sequential function chart
  - Structured text (similar to Pascal)
- 128 KB Flash memory for user program
- 128 KB RAM for user data
- 16 KB battery buffered RAM for no-voltage safe data
- Battery buffered real time clock
- Monitoring contact for RUN status of the PLC
- 35 mm width

**Circuit diagram**



**Additional information**

- Data sheet input module IP 5502
- Data sheet output module IP 5503
- Data sheet emergency stop monitor BH 5922
- Data sheet power supply IR 5592
- Data sheet text display EQ 5973

**Approvals and marking**



**Application**

The PLC runs a user program edited with the programming software PN 5501. The program can process local I/Os on the PLC as well as remote I/Os via the CANopen bus.

**Indicators**

- |                     |  |
|---------------------|--|
| green LED „ON“:     | on, when supply connected                                    |
| yellow LED „BUS“:   | on, when bus is active                                       |
| yellow LED „RUN“:   | on, when PLC in RUN state                                    |
|                     | flashing, when failure                                       |
| green LED „I0, I1“: | on, when corresponding input is active (I0/C0-, I1/C1-)      |
| red LED „O1, O2“:   | on, when corresponding output relay is active (03/04, 13/14) |

## Setting and adjustment

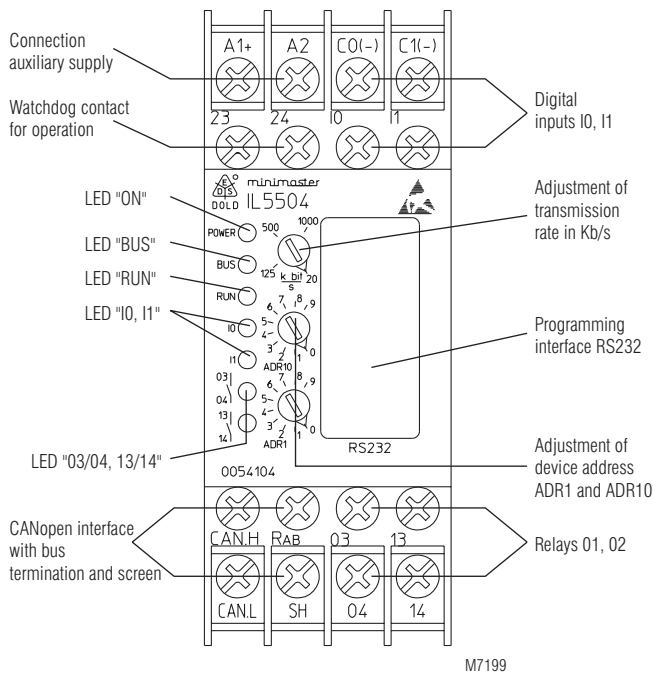

## Adjustment of address:

To allow communication on the CANopen-Bus the device address has to be set with the 2 rotational switches between 1 ... 99.

## Set-up procedure:

- 1.) Connect device to CANopen-bus
- 2.) Terminate bus on both ends with bridge between CAN-H and R<sub>ab</sub>
- 3.) Adjust transmission speed
- 4.) Set knot address
- 5.) Transmit program from PC to PLC IL 5504 with programming software and store it.

## Technical data

### Auxiliary voltage

**Auxiliary voltage U<sub>H</sub> A1/A2:** DC 24 V  
**Voltage range:** 0,8 ... 1,1 U<sub>N</sub>  
**Nominal consumption:** 1,4 W

### Input

**Inputs:** 2 digital inputs according to IEC/EN 61131-2 galvanic separated by optocouplers  
**Input voltage:** DC 24 V  
**Signalverzögerung:** approx. 2 ms

### Output

**Contacts:** IL 5504.22: 2 relay outputs  
 1 monitoring contact 23-24  
**Thermal current I<sub>th</sub>:** 2 A  
**Switching capacity** to AC 15: 3 A / AC 230 V IEC/EN 60 947-5-1  
**Switching capacity:** at DC 24 V: 48 W  
 at AC 230 V: 460 VA  
**Short circuit strength**  
**max. fuse rating:** 4 AgL IEC/EN 60 947-5-1  
**Mechanical life:** > 10<sup>6</sup> switching cycles

### Programming interface RS232

**Wire:** Null Modem wire link  
**Transmission parameter:** 57,6 KBaud, 8N1  
 The auxiliary voltage U<sub>H</sub> is not galvanically separated from the programming interface.

### CANopen interface

**Wire:** screened twisted pair  
**Transmission speed:** adjustable 20 Kb/s, 125 Kb/s, 500 Kb/s, 1 Mb/s,  
**Attention:** Both ends of the 2-wire bus have to be terminated with a bridge between CAN\_H and R<sub>ab</sub>. The auxiliary voltage U<sub>H</sub> is not galvanically separated from the CANopen interface.



## General data

**Buffer for RAM and Realtime clock:** 3 years  
**Zykluszeit:** approx. 10 ms + (0,4 ms per translated 1 Kb user program)

## Technical data

### Immunity against phase failure:

20 ms

### Operating mode:

Continuous operation

### Temperature range:

- 20 ... + 60°C

### Clearance and creepage distances

overvoltage category / contamination level

auxiliary voltage, CANopen interface to digital inputs:

1,5 kV / 2

IEC 60 664-1

digital inputs to

digital inputs:

1,5 kV / 2

IEC 60 664-1

auxiliary voltage,

CANopen interface to

relay outputs:

4 kV / 2

IEC 60 664-1

relay outputs to relay

outputs:

4 kV / 2

IEC 60 664-1

### EMC

Electrostatic discharge:

8 kV (air)

IEC/EN 61 000-4-2

HF-irradiation:

10 V/m

IEC/EN 61 000-4-3

Fast transients:

2 kV

IEC/EN 61 000-4-4

Surge voltages

between

wires for power supply:

1 kV

IEC/EN 61 000-4-5

between wire and ground:

2 kV

IEC/EN 61 000-4-5

Interference suppression:

Limit value class B

EN 55 011

### Degree of protection

Housing:

IP 30

IEC/EN 60 529

Terminals:

IP 20

IEC/EN 60 529

### Housing:

Thermoplastic with V0-behaviour

according to UL subject 94

### Vibration resistance:

amplitude 0,35 mm

frequency 10 ... 55 Hz, IEC/EN 60 068-2-6

### Climate resistance:

20 / 060 / 04

IEC/EN 60 068-1

### Terminal designation:

### Wire connection:

2 x 2,5 mm<sup>2</sup> solid or

2 x 1,5 mm<sup>2</sup> stranded wire with sleeve

DIN 46 228-1/-2/-3/-4

### Wire fixing:

Flat terminals with self-lifting

clamping piece IEC/EN 60 999-1

### Mounting:

### Weight:

DIN rail

150 g

IEC/EN 60 715

## Dimensions

### Width x height x depth:

35 x 90 x 58 mm

## Standard type

IL 5504.22 DC 24 V

Article number: 0054104

- 2 relay outputs
- 1 monitoring contact
- 2 digital inputs DC 24 V
- CANopen interface
- Auxiliary supply  $U_H$ : DC 24 V
- Width: 35 mm

## Accessories

Programming software: PN5501  
Article number: 0052860

Programming cable: OA5529  
Article number: 0054950

## Application example

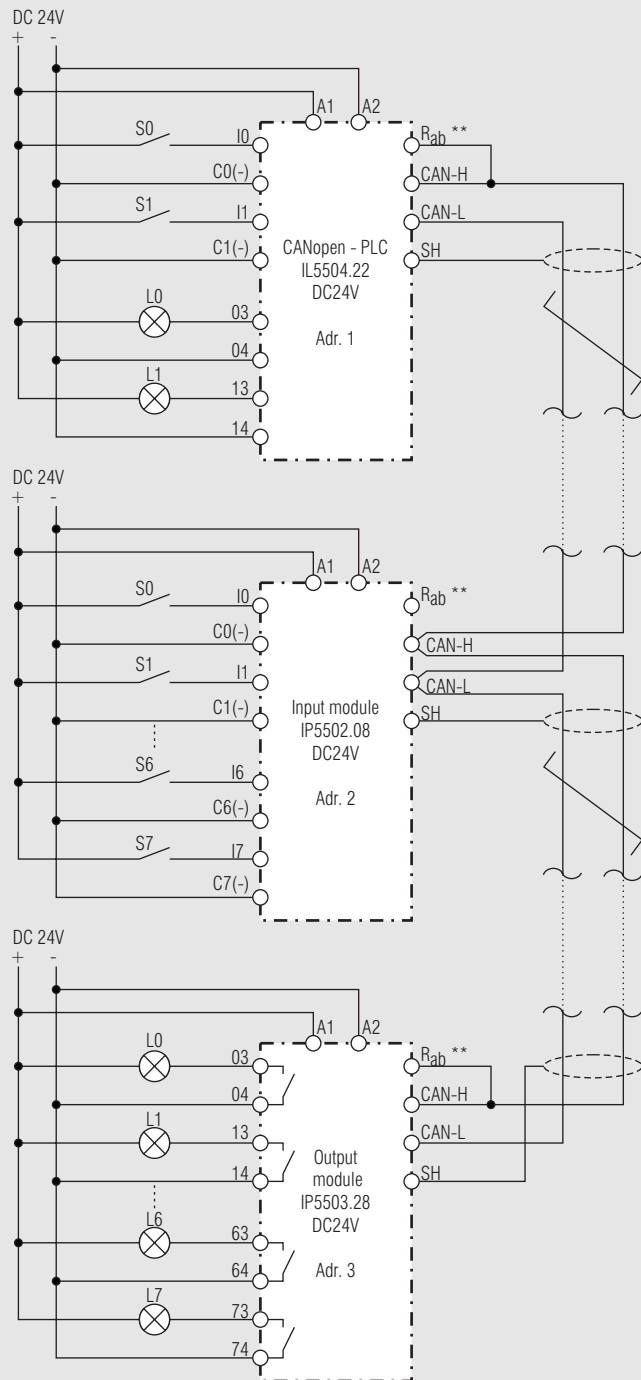

\*\* Both ends of the 2-wire bus have to be terminated with a bridge between CAN-H and R<sub>ab</sub>.

M7853

