

Softstarter IL 9017, SL 9017
ministart

0224305



- Increases life of 1-phase squirrel motors and mechanical drives
- Devices available in 2 enclosure version:
 IL 9017: depth 61 mm with terminals at the bottom for installations systems and industrial distribution systems according to DIN 43 880
 SL 9017: depth 100 mm with terminals at the top for cabinets with mounting plate and cable duct
- For single phase motors up to 1,5 kW
- Adjustable ramp time and starting torque
- Semiconductors will be bridged after start up
- LED indication
- Width 35 mm

Function diagram

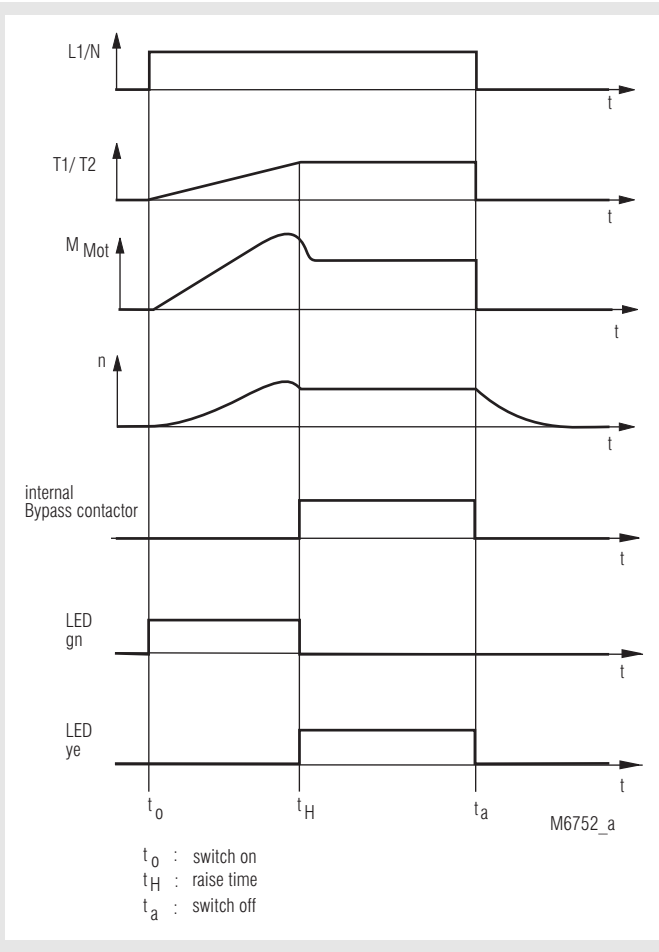

Approvals and marking

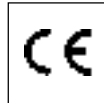

Applications

- Drives with gears, belts or chains
- Conveyor belts, fans
- Pumps, compressors

Function

Softstarters are electronic devices designed to enable 1-phase induction motors to start smoothly IL 9017. Slowly ramps up the current, allowing the motor torque to build up slowly. This reduces the mechanical stress on the machine and prevents damage to conveyed material. When the motor is up to full speed the semiconductors in IL 9017 are bridged to prevent internal power losses and heat build up.

Indication

LED green: softstart active
 LED yellow: softstart is finished

Principle of operation

Terminal L1 is connected to the mains contactor, terminal N to neutral, the motor is connected to terminals T1, T2. As soon as power is connected to terminal L1, the softstart will commence. Potentiometer " t_{an} " (1 - 10 sec.) adjusts the ramp time (time the motor takes to get to full speed) and potentiometer " M_{an} " adjusts the start voltage (20 - 70% V_{nom}). When the softstart is complete the internal semiconductor is automatically bridged.

Block diagram

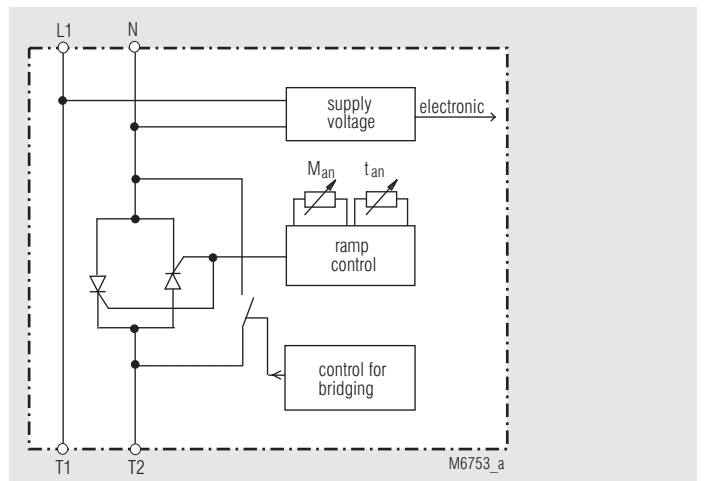

Notes

The motor load must always be connected as continuous operation of the softstart with no load may cause overheating of the motor and softstart. It is recommended that the softstart is protected by superfast semiconductor fuses rated as per the current rating of the softstart or motor. However, standard line and motor protection is acceptable, but for high starting frequencies motor winding temperature monitoring is recommended.

Technical data

Nominal voltage U_N:	AC 230 V -20 % +10 %
Nominal motor power P_N:	1,5 kW
Min. motor power:	approx. 10 % of rated motor power
Nominal current:	10 A
External fuse (optional) superfast:	20 A
Starting voltage:	20 ... 70 %
Acceleration time at starting voltage 20 %:	0,1 ... 10 s
Recovery time:	200 ms
Switching frequency:	10/h at $3 \times I_r / t_{an} = 10 \text{ s}, \vartheta_U = 20 \text{ }^\circ\text{C}$
Power consumption:	1,4 VA

General data

Operating mode:	continuous operation
Temperature range:	0 ... +55 °C
Storage temperature:	-25 ... +75 °C
Clearance and creepage distances	
overvoltage category / contamination level:	4 kV / 2 IEC 60 664-1
EMC	
Electrostatic discharge:	8 kV (air) IEC/EN 61 000-4-2
HF irradiation:	10 V / m IEC/EN 61 000-4-3
Fast transients:	2 kV IEC/EN 61 000-4-4
Surge voltages between wires for power supply:	1 kV IEC/EN 61 000-4-5
between wire and ground:	2 kV IEC/EN 61 000-4-5
HF wire guided:	10 V IEC/EN 61 000-4-6
Interference suppression:	Limit value class B EN 55 011
Degree of protection:	Housing: IP 40 IEC/EN 60 529 Terminals: IP 20 IEC/EN 60 529
Housing:	Thermoplastic with V0 behaviour according to UL subject 94
Vibration resistance:	Amplitude 0,35 mm, IEC/EN 60 068-2-6 frequency 10 ... 55 Hz
Climate resistance:	0 / 055 / 04 IEC/EN 60 068-1
Terminal designation:	EN 50 005
Wire connection:	2 x 2,5 mm ² solid or 2 x 1,5 mm ² stranded ferruled DIN 46 228-1/-2/-3
Wire fixing:	Flat terminals with self-lifting clamping piece IEC/EN 60 999-1 DIN rail IEC/EN 60 715
Mounting:	
Weight	
IL 9017:	135 g
SL 9017:	164 g

Dimensions

Width x height x depth

IL 9017:	35 x 90 x 61 mm
SL 9017:	35 x 90 x 100 mm

Standard type

IL 9017 AC 230 V 1,5 kW	
Article number:	0049323
SL 9017 AC 230 V 1,5 kW	
Article number:	0050603
• Nominal voltage U_N :	AC 230 V
• For motors up to 1,5 kW	
• Width:	35 mm

Ordering example

IL 9017	AC 230 V	1,5 kW	
			Nominal motor power
			Nominal voltage
			Type

Installation

These units must be mounted on a vertical mounting area with the connections in a vertical plane, i.e. top to bottom. Ensure that no external heat source is placed below the unit and a 40 mm air gap is maintained above and below. Other devices may be directly mounted either side of the unit.

Setup procedure

1. Set potentiometer " M_{an} " to minimum (fully anti-clockwise)
Set potentiometer " t_{an} " to maximum (fully clockwise)
2. Start the motor and turn potentiometer " M_{an} " up until the motor starts to turn without excessive humming. Stop the motor and restart.
3. Adjust potentiometer " t_{an} " to give the desired ramp time.
Stop and restart the motor, readjusting the potentiometers until the desired starting characteristics are achieved.

- **Attention:** If the ramp-up time is adjusted to short, the internal bridging contact closes before the motor is on full speed.
 This may damage the bridging contactor or bridging relay.

Safety instruction

- Never clear a fault when the device is switched on
- The user must ensure that the device and the necessary components are mounted and connected according to the locally applicable regulations and technical standards.
- Adjustments may only be carried out by qualified specialist staff and the applicable safety rules must be observed.

Application example

