

Reversing contactor BH 9253
powerswitch

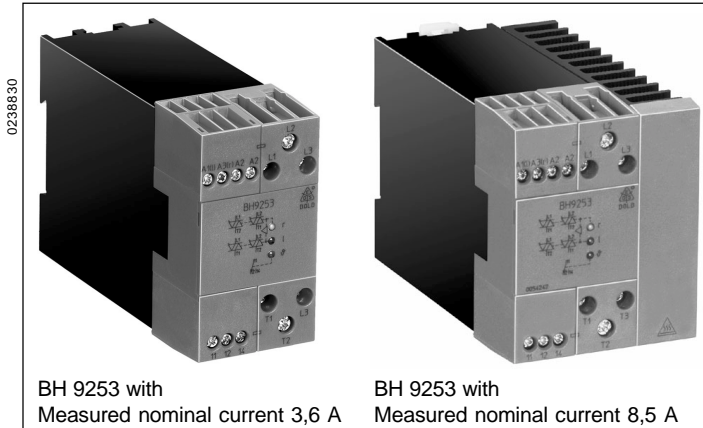

- According to IEC/EN 60 947-1, IEC/EN 60 947-4-2
- Switching at zero-crossing
- To reverse 3 phase squirrel cage motors up to 5,5 kW at 400 V, 7,5 kW at 500 V
- Electrical interlocking of both directions
- Temperature monitoring to protect the power semiconductors
- Measured nominal current up to 11,5 A
- LEDs for status indication
- Galvanic separation between control circuit and power circuit
- 45 mm; 67,5 mm; 112,5 mm width

Function diagram

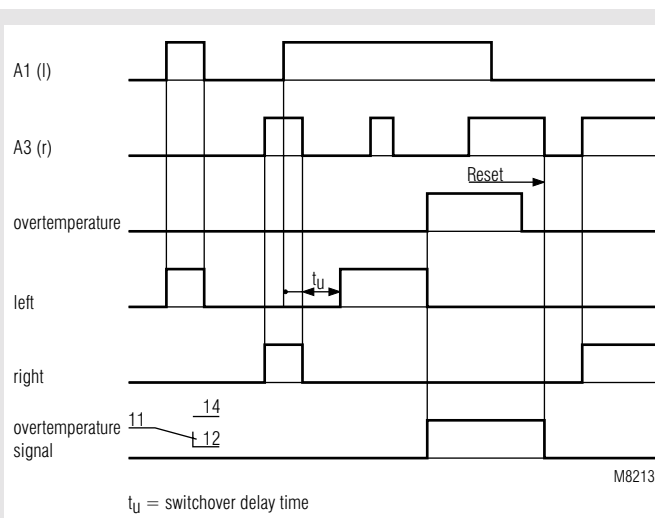

Approvals and marking



Function

The reversing contactor BH 9253 is used to reverse the direction of 3-phase squirrel cage motors by switching 2 phases. An electrical interlocking disables the control of both directions at the same time. The reversing contactor has a short on and off delay time. When reversing the phases a switchover delay is guaranteed.

Temperature sensing

To protect the power semiconductors the unit incorporates temperature monitoring. When overtemperature is detected the power semiconductors switch off and an output relay as well as a red LED is activated. This state is stored. When the temperature is back to normal the semiconductors can be activated again by switching off and on the control voltage.

Indication

- yellow LED "Links": on, when left direction active
- yellow LED "Rechts": on, when right direction active
- red LED: on, when overtemperature

Circuit diagram

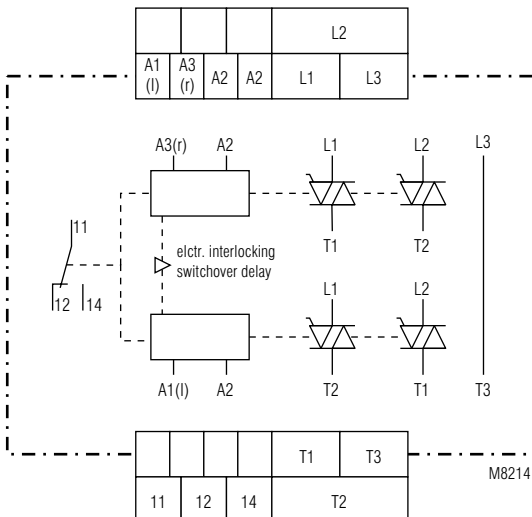

Technical data

Input

Nominal voltage U_N:	AC/DC 24 V; AC 110 ... 127 V, AC 220 ... 240 V, AC 288 V, AC 400 V
Voltage range:	AC: 0,8 ... 1,1 U_N DC: 0,8 ... 1,25 U_N
Nominal consumption at AC 230 V:	4 VA, 0,8 W
at DC 24 V:	0,3 W
Nominal frequency:	50 / 60 Hz
Pick-up delay:	max. 30 ms
Drop-out delay:	typically 25 ms
Switch-over delay t_v:	100 ms (other values on request)
Permissible residual voltage:	30 % U_N

Load output

Motor power:	max. 5,5 kW at 400 V, 7,5 kW at 500 V start max. 2 s
---------------------	---

Device without heat sink

Measured thermal current ¹⁾ :	5 A
Example for operation mode for motor with 1,5 kW / 400 V:	3,6 A: AC 53a: 6-2: 100-140 ²⁾ according to IEC/EN 60 947-4-2

Device with heat sink

width 67,5 mm	
Measured thermal current ¹⁾ :	10 A
Example for operation mode for motor with 4 kW / 400 V:	8,5 A: AC 53a: 6-2: 100-160 ²⁾ according to IEC/EN 60 947-4-2

Device with heat sink

width 112,5 mm	
Measured thermal current ¹⁾ :	20 A
Example for operation mode for motor with 5,5 kW / 400 V:	11,5 A: AC 53a: 6-2: 100-260 ²⁾ according to IEC/EN 60 947-4-2

¹⁾ The measured thermal current is the arithmetic mean of starting and measured nominal current of the motor in a turn cycle.

²⁾ Def.: **11,5 A: AC 53a: 6-2: 100-260**

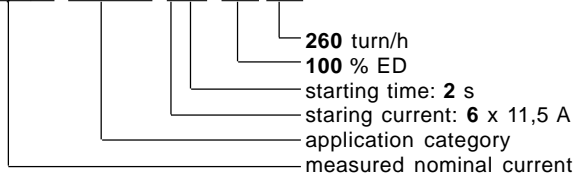

The max. starting current of 100A for 1s, 70 A for 2s and 60A for 5s should not be passed.

Current reduction:	over 40 °C 0,2 A / °C
Load voltage range:	AC 24 ... 500 V
Peak inverse voltage:	1 200 Vp
Frequency range:	50 / 60 Hz
Surge current 10 ms:	350 A
Semiconductor fuse:	610 A ² s
Varistor voltage:	AC 510 V

Monitoring output

Contacts BH 9253.11:	1 changeover contact
Thermal current I_{th}:	5 A
Switching capacity at AC 15	
NO:	3 A / AC 230 V IEC/EN 60 947-5-1
NC:	1 A / AC 230 V IEC/EN 60 947-5-1
Short circuit strength max. fuse rating:	4 A gL IEC/EN 60 947-5-1

General data

Operating mode:	Continuous operation
Temperature range:	- 20 ... + 40 °C
Clearance and creepage distances overvoltage category / contamination level:	4 kV / 2 IEC 60 664-1

Technische Daten

EMC

Surge voltages:	5 kV / 0,5 J
HF-interference:	2,5 kV
Electrostatic discharge:	8 kV (air) IEC/EN 61 000-4-2
HF irradiation:	10 V / m IEC/EN 61 000-4-3
Fast transients:	4 kV IEC/EN 61 000-4-4
Surge voltages between wires for power supply:	1 kV IEC/EN 61 000-4-5
HF wire guided:	10 V IEC/EN 61 000-4-6
Interference suppression:	Limit value class B EN 55 011

Degree of protection:

Housing:	IP 40 IEC/EN 60 529
Terminals:	IP 20 IEC/EN 60 529

Housing:

Housing:	Thermoplastic with V0 behaviour according to UL subject 94
Vibration resistance:	Amplitude 0,35 mm IEC/EN 60 068-2-6 frequency 10 ... 55 Hz
Climate resistance:	20 / 040 / 04 IEC/EN 60 068-1
Terminal designation:	EN 50 005

Wire connection

Load terminals:	1 x 10 mm ² solid or 1 x 6 mm ² stranded ferruled 2 x 2,5 mm ² solid or 2 x 1,5 mm ² stranded ferruled DIN 46 228-1/-2/-3/-4
Control terminals:	terminal screws M3,5; box terminals with self-lifting wire protection DIN rail IEC/EN 60 715
Wire fixing:	
Mounting:	
Weight:	

Width 45 mm:	420 g
Width 67,5 mm:	640 g
Width 112,5 mm:	1 060g

Dimensions

Width x height x depth:	45 x 84 x 121 mm 67,5 x 84 x 121 mm 112,5 x 84 x 121 mm
--------------------------------	---

Standard type

BH 9253.11 AC 220 ... 240 V 50 / 60 Hz 3,6 A 100 ms	
Article number:	
• Output:	1 changeover contact
• Nominal voltage U_N :	AC 220 ... 240 V
• Switchover delay:	100 ms
• Width:	45 mm

Ordering example

BH 9253 .11 AC 220...240 V 50 / 60 Hz 3,6 A 100 ms	
	Switchover delay
	Measured nominal current
	Nominal frequency
	Nominal voltage
	Contacts
	Type

Application example

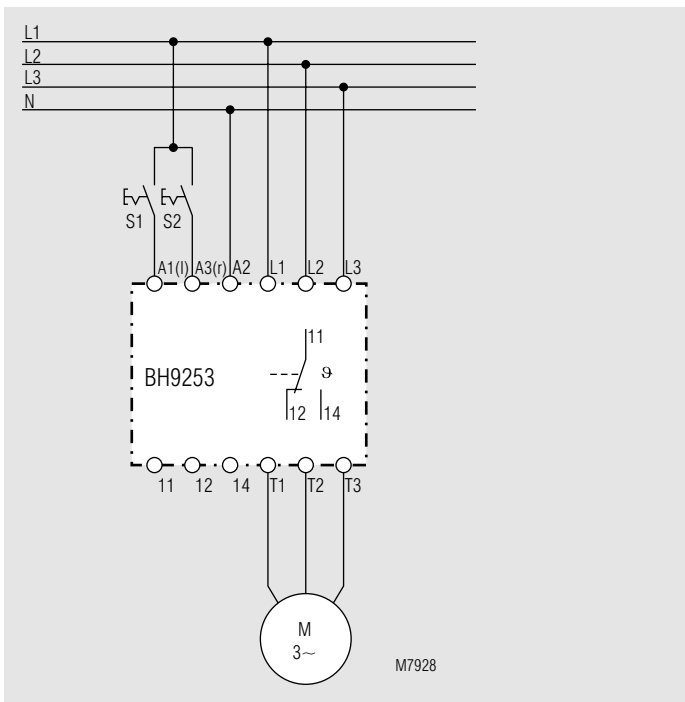

ATTENTION!



A1 and A3 has to be connected to the same potential. the common connection is terminal A2.

