

Reverse power relay IR 9140 varimeter

0224317



- According to IEC/EN 60 255, DiN VDE 0435-303
- Measures effective power independent of curve shape e.g. to be operated with frequency converters
- For single- or 3-phase systems
- Wide auxiliary voltage range
- Adjustable response value 5 ... 100 % reverse power
- Adjustable hysteresis 0 ... 50 % of response value
- Nominal current 5 or 10 A (on request)
- Adjustable operate delay
- Open or closed circuit operation
- LED indicators for auxiliary supply and state of output contacts
- 2 changeover contacts
- Width 105 mm

Function diagram

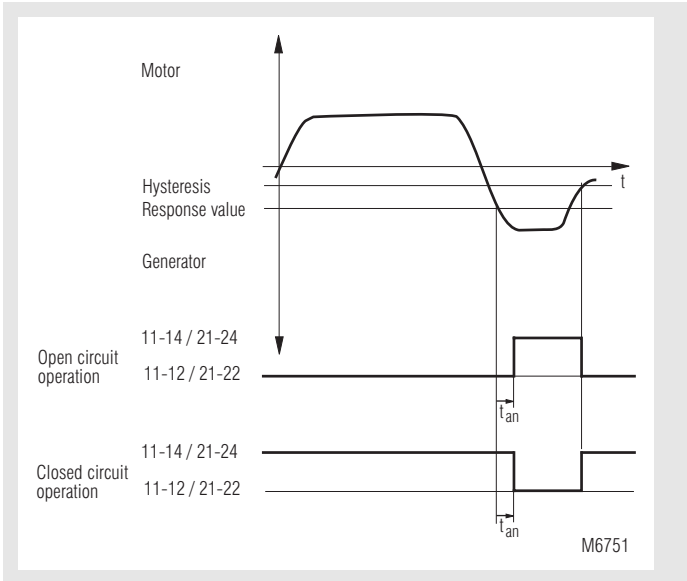

Approvals and marking



Applications

The reverse power relay monitors the direction of the energy transport in a voltage system. This might be necessary on connection points between public mains and industrial system, when operation generator sets or emergency power supplies, when motors can run as generator, etc.

Function

The instrument is designed for a max. current of 10 A. If the current is higher a current transformer must be used. The setting value of the reverse power can be setted from 5 to 100 %.

The reverse power ist calculated using the formula:

$$U \times I \times \cos \varphi$$

With a response value of 100 % this is:

$$230 \text{ V} \times 5 \text{ A} \times 1 = 1150 \text{ VA}$$

$$230 \text{ V} \times 10 \text{ A} \times 1 = 2300 \text{ VA}$$

Indicators

- green LED: on, when auxiliary supply connected
- yellow LED: on, when output relay active

Circuit diagrams

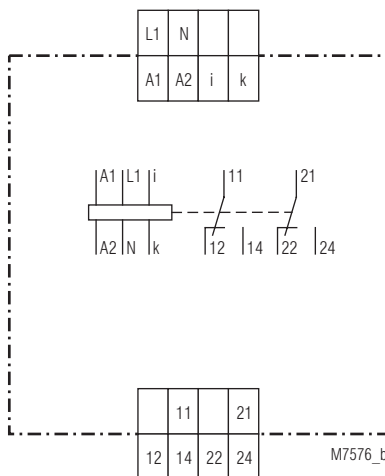

Device type for $U_N = \text{AC } 230 \text{ V}$

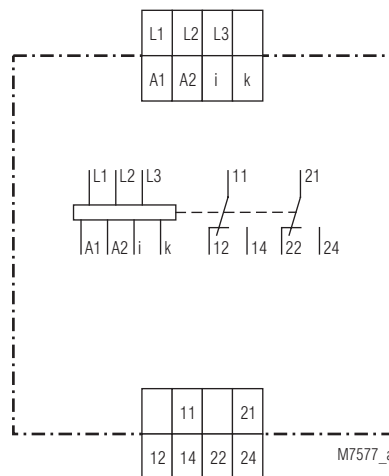

Device type for $U_N = 3 \text{ AC } 400 \text{ V}$

Notes

When installing the reverse power relay it is necessary to make sure that the measuring voltage (terminals L1, N) and the current input res. CT (terminals i, k) are connected to the same phase. With model IR 9140.12/0__ terminal L1 must be bridged with terminal i. The CT must not be grounded on secondary side. On model IR 9140.12/2___ the link is not necessary and the CT can be grounded. If the output relay already reacts on right direction of current, the wires on terminals i and k must be changed against each other.

With the potentiometer "Hyst" a hysteresis of 0 to 50 % can be set. This value relates to the setted response value. 2 versions of the IR 9140 are available with or without neutral. In this case the single phase unit with the terminals L, N is suitable. For systems without neutral the 3p3w version with the terminals L1, L2, L3 must be used.

Technical data

Measuring circuit

Nominal voltage U_N

L1-N: AC 230 V
L1-L2-L3: 3 AC 400 V

Voltage range:

0 ... 1,2 U_N

Response value

IR 9140.12/0__ : 5 ... 100 % reverse power

IR 9140.12/2__ : 2 ... 20 % reverse power

Hysteresis:

0 ... 50 % of setted response value

Max. overvoltage: 1,2 U_N continuously

Frequency range: 45 ... 65 Hz

Nominal current: 5 A

10 A (on request)

Operate delay t_{an} : adjustable, 2 ... 20 s

Nominal consumption

voltage input: < 1 VA

current input: < 1 VA

Auxiliary circuit

Auxiliary voltage A1, A2: AC 230, 240, 400, 415 V

Voltage range: 0,75 ... 1,2 U_H

Frequency range: 45 ... 65 Hz

Nominal consumption: < 4 VA

Output

Contacts

IR 9140.12: 2 changeover contacts

Thermal current I_{th} : 4 A

Mechanical life: $\geq 30 \times 10^6$ switching cycles

General data

Operating mode: Continuous operation

Temperature range: -20 ... +60°C

Clearance and creepage distances

Overvoltage category / contamination level: 4 kV / 2 IEC 60 664-1

EMC

Electrostatic discharge: 8 kV (air) IEC/EN 61 000-4-2

HF irradiation: 10 V / m IEC/EN 61 000-4-3

Fast transients: 2 kV IEC/EN 61 000-4-4

Surge voltages

between

wires for power supply: 1 kV IEC/EN 61 000-4-5

between wire and ground: 2 kV IEC/EN 61 000-4-5

Interference suppression: Limit value class B EN 55 011

Degree of protection: Housing: IP 40 IEC/EN 60 529

Terminals: IP 20 IEC/EN 60 529

Housing: Thermoplastic with V0 behaviour

according to UL subject 94

Vibration resistance: Amplitude 0,35 mm

frequency 10 ... 55 Hz IEC/EN 60 068-2-6

20 / 060 / 04 IEC/EN 60 068-1

Terminal designation: EN 50 005

Wire connection: 2 x 2,5 mm² solid or

2 x 1,5 mm² stranded ferruled

DIN 46 228-1/-2/-3/-4

Technical data

Wire fixing: Flat terminals with self-lifting clamping piece IEC/EN 60 999-1

Mounting: DIN rail IEC/EN 60 715

Weight: 500 g

Dimensions

Width x height x depth: 105 x 90 x 59 mm

Standard type

IR 9140.12/201 3 AC 400 V 5 A AC 230 V 20 s

Article number:

- Open circuit operation
- 3-phase systems without neutral
- Response value: 2 ... 20 %
- Nominal voltage U_N : 3 AC 400 V
- Nominal current: 5 A
- Auxiliary voltage U_H : AC 230 V
- Operate delay: 2 ... 20 s
- Width: 105 mm

Variants

- IR 9140.12 / _ _ _
- 0 single phase system with neutral
 - 1 3-phase systems without neutral
 - 0 open circuit operation
 - 1 closed circuit operation
 - 0 bridge L1/i required, response value 5 ... 100 % (old version)
 - 2 without bridge L1/i, response value 2...20%

Ordering example for Variants

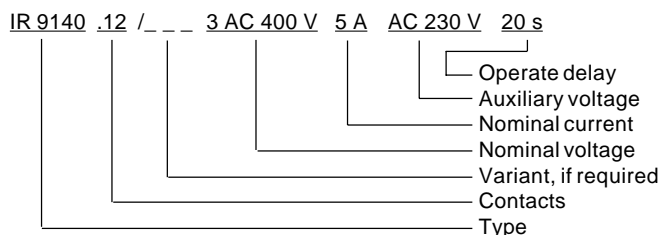

Connection examples

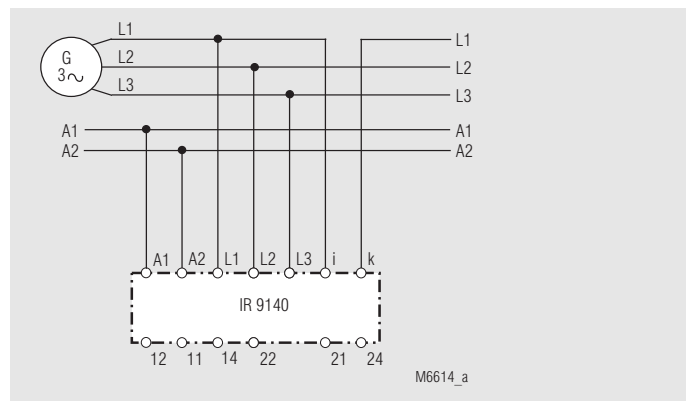

For 3p3w systems at $I < 5$ A

Connection examples

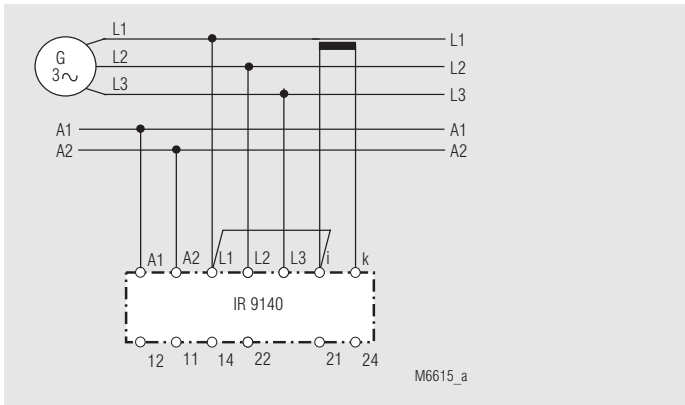

For 3p3w systems at $I > 5$ A with current transformer.
Link L1/i is only necessary on model IR 9140.12/0_._.

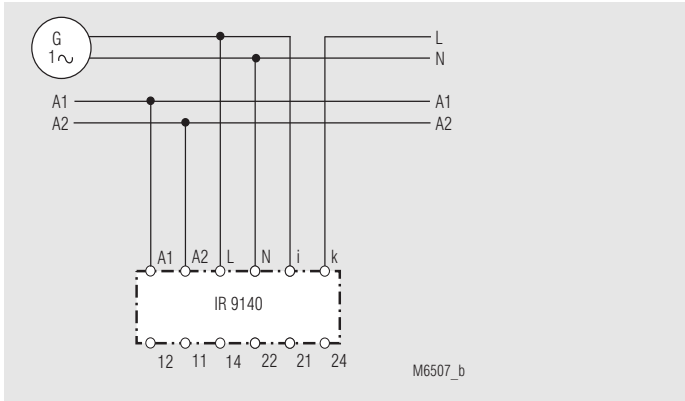

For single phase or 3p4w systems at $I < 5$ A

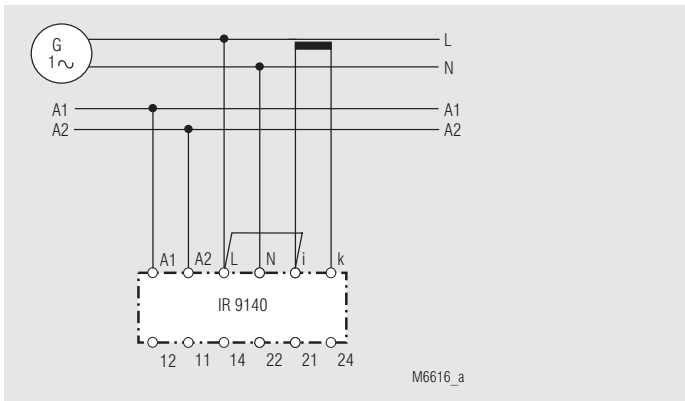

For single phase or 3p4w systems at $I > 5$ A with current transformer.
Link L1/i is only necessary on model IR 9140.12/0_._.

