

## Over- and undervoltage relay

IL 9077, IP 9077, SL 9077, SP 9077

varimeter

0222093

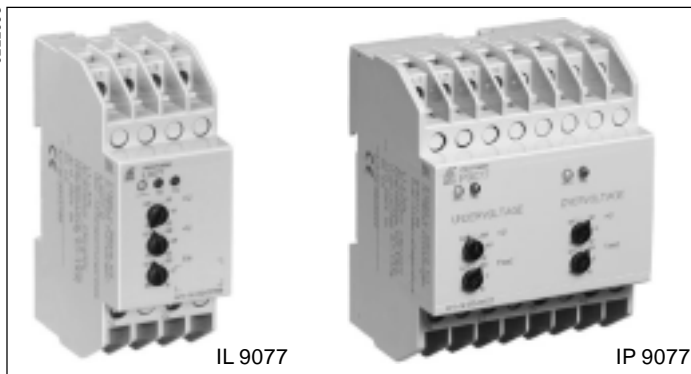

- According to IEC/EN 60 255, DIN VDE 0435-303
- **Devices available in 2 enclosure versions:**
  - I-model:** depth 59 mm, with terminals at the bottom for installation systems and industrial distribution systems according to DIN 43 880
  - S-model:** depth 98 mm, with terminals at the top for cabinets with mounting plate and cable duct
- Identification of overvoltage, undervoltage and phase failure
- With asymmetry identification as an option
- Mains fault diagnostics with a number of LEDs
- Setting values for overvoltage and undervoltage can be set separately
- Large setting ranges  $0,9 \dots 1,3 U_N$  and  $0,7 \dots 1,1 U_N$
- Time delay variable between  $0,1 \dots 20$  s
- Closed circuit operation
- No auxiliary voltage
- Independent of phase sequence
- As option with phase sequence detection
- Single-phase connection possible
- Optionally for 3P3W Systems
- 2 changeover contacts, at IP/SP 9077 2 x 2 changeover contacts
- IL 9077, SL 9077: width 35 mm
- IP 9077, SP 9077: width 70 mm

### Function diagram IL 9077

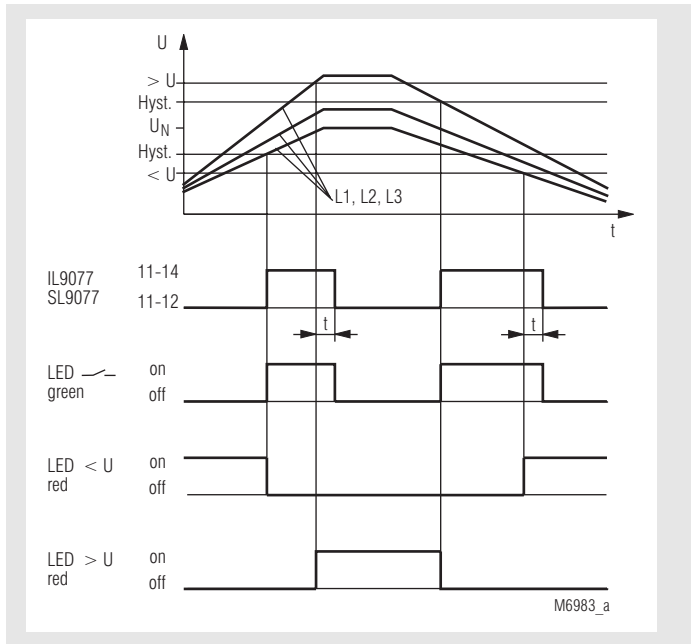

### Approvals and marking

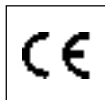

### Application

Monitoring of three-phase voltage systems to identify overvoltage and undervoltage, e.g. to monitor in-house generation equipment in accordance with VDE 0100.

### Function

All 3 phase voltages are measured with N (L1 and L2 are measured against L3 in the case of equipment without an N connection). If they are in the acceptable range, a green LED goes on and the output relay is activated.

If at least one phase exceeds the setting value for overvoltage (variable between  $0,9 \dots 1,3 U_N$ ) or if at least one phase falls short of the setting value for undervoltage (variable between  $0,7 \dots 1,1 U_N$ ), the output relay releases after the set time delay and the green LED goes off (fault state). 2 red LEDs then indicate the cause of the fault:

- Undervoltage " $< U$ "
- Overvoltage " $> U$ "

When all 3 phase voltages are below the chosen setting value for overvoltage and above the chosen setting value for undervoltage again, the relevant red LED goes out, the output relay is activated again and the green LED goes on again (acceptable state).

When the system returns to an acceptable state, there is a hysteresis of about 4 % of the set value with both the set voltage thresholds.

On the unit with phase sequence detection IL/SL 9077/003 (only available without neutral) the wrong phase sequence is handled like undervoltage: The red LED " $< U$ " is active and the output relay switches off.

The model with asymmetry identification IL/SL 9077/010 monitors the symmetry of the three-phase voltage system as well. When all 3 voltages are in the acceptable range between the two setting values here, but there is voltage asymmetry of more than about 6 ... 8 %, the output relay releases after the set time delay and the LED that is green when the state is acceptable goes red. (This model can, for example, also be used for immediate identification of the regeneration of failed phases by feedback). The IP/SP 9077.39 is an under- and overvoltage relay with separate output relays (each with 2 changeover contacts) for undervoltage and overvoltage monitoring. For every output a separate delay  $0,1 \dots 20$  s is adjustable.

### Circuit diagram

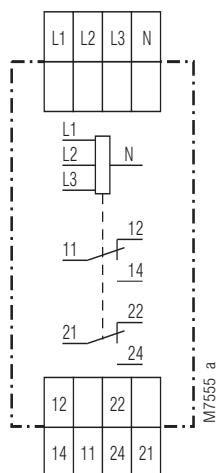

IL 9077.12, SL 9077.12

## Function diagram IP 9077

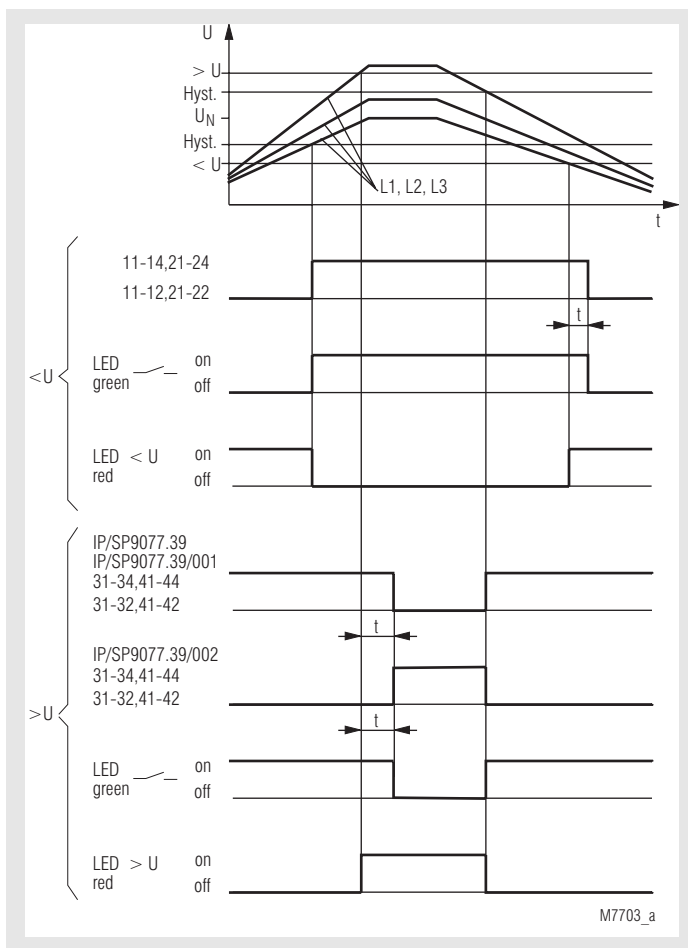

M7703\_a

## Circuit diagrams

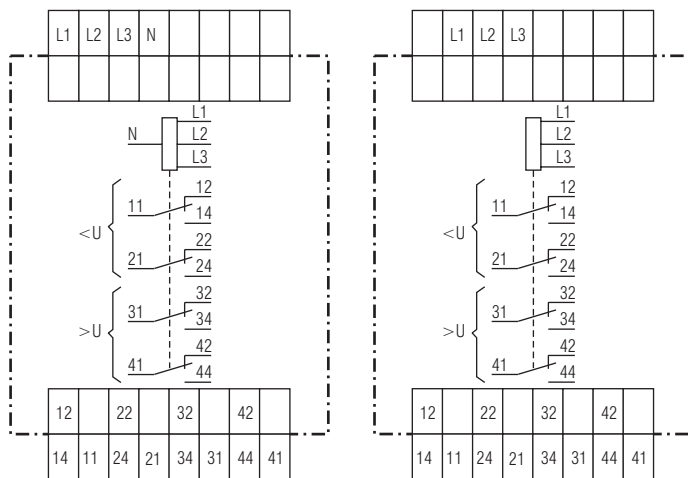

M7686\_a

M7687\_a

IP 9077.39, SP 9077.39

IP 9077.39/001, SP 9077.39/001  
IP 9077.39/002, SP 9077.39/002

## Indicators

green LED :  
green LED goes red:

state  
voltage asymmetry  
(only IL/SL 9077/010)  
fault message / undervoltage  
fault message / overvoltage

red LED " $< U$ ":  
red LED " $> U$ ":

## Notes

The terminals L1, L2 and L3 have to be bridged if the relay is used in single phase systems. (For 3p3w units L1 and L2 have to be linked).  
The maximum fault delay amounts to only about 0.6 s if there is a total failure of phase L3.  
The overvoltage output on IP/SP 9077.39/002 can only switch if the voltage between L2 and L3 is  $> 0,7 U_N$  as the unit works without auxiliary supply.

## Technical data

### Input

**Nominal voltage  $U_N$ :** 3/N AC 100 / 58, 400 / 230 V  
3 AC 100, 400 V  
other voltages on request  
**Voltage range:** 0,7 ... 1,3  $U_N$   
**Maximum overload:** 1,35  $U_N$ , permanent  
**Nominal consumption:** approx. 8 VA (L3-N)  
(approx. 16 VA for IP 9077)

**Nominal frequency:** 50 / 60 Hz

### Setting ranges

**Setting value for overvoltage " $> U$ ":** variable between 0,9 ... 1,3  $U_N$   
**Setting value for undervoltage " $< U$ ":** variable between 0,7 ... 1,1  $U_N$   
**Hysteresis:** approx. 4 % of the set value in each case  
**Time delay:** variable between 0,1 ... 20 s  
**Threshold for asymmetry identification**  
IL/SL 9077/010: approx. 6 ... 8 % phase asymmetry

### Output

**Contacts**  
IL/SL 9077.12: 2 changeover contacts  
IP/SP 9077.39: 2 x 2 changeover contacts  
**Thermal current  $I_{th}$ :** 4 A  
**Switching capacity**  
to AC 15:  
NO contact: 5 A / AC 230 V IEC/EN 60 947-5-1  
NC contact: 2 A / AC 230 V IEC/EN 60 947-5-1  
**Electrical life:** IEC/EN 60 947- 5-1  
to AC 15 at 1 A, AC 230 V:  $\geq 1,5 \times 10^5$  switching cycles  
**Short circuit strength**  
**max. fuse rating:** 4 A gL IEC/EN 60 947-5-1  
**Mechanical life:** 30 x  $10^6$  switching cycles

### General data

**Operating mode:** Continuous operation  
**Temperature range:** - 20 ... + 60°C  
**Clearance and creepage distances**  
overvoltage category / contamination level: 4 kV / 2 IEC 60 664-1  
**EMC**  
Electrostatic discharge: 8 kV (air) IEC/EN 61 000-4-2  
HF irradiation: 10 V / m IEC/EN 61 000-4-3  
Fast transients: 4 kV IEC/EN 61 000-4-4  
**Surge voltages**  
between wires for power supply: 2 kV IEC/EN 61 000-4-5  
between wire and ground: 2 kV IEC/EN 61 000-4-5  
**Interference suppression:** Limit value class B EN 55 011  
**Degree of protection:** Housing: IP 40 IEC/EN 60 529  
Terminals: IP 20 IEC/EN 60 529  
**Housing:** Highly non-flammable thermoplastic with V0 behaviour according to UL subject 94  
**Vibration resistance:** Amplitude 0,35 mm, frequency 10 ... 55 Hz IEC/EN 60 068-2-6  
**Climate resistance:** 20 / 060 / 04 IEC/EN 60 068-1  
**Wire connection:** 2 x 2,5 mm<sup>2</sup> solid or 2 x 1,5 mm<sup>2</sup> stranded ferruled  
DIN 46 228-1/-2/-3/-4  
DIN rail IEC/EN 60 715

### Mounting:

**Weight**  
IL 9077: 110 g  
SL 9077: 137 g  
IP 9077: 210 g  
SP 9077: 259 g

## Technical data

### Dimensions

#### Width x height x depth

IL 9077:	35 x 90 x 59 mm
SL 9077:	35 x 90 x 98 mm
IP 9077:	70 x 90 x 59 mm
SP 9077:	70 x 90 x 98 mm

### Standard type

IL 9077.12	3/N AC 400 / 230 V	0,1 ... 20 s	
Article number:	0045788		stock item
• Output:	2 changeover contacts		
• Nominal voltage $U_N$ :	3/N AC 400/230 V		
• Deenergised on trip			
• Variable time delay 0,1 ... 20 s			
• Width:	35 mm		
SL 9077.12	3/N AC 400 / 230 V	0,1 ... 20 s	
Article number:	0054758		
• Output:	2 changeover contacts		
• Nominal voltage $U_N$ :	3/N AC 400/230 V		
• Deenergised on trip			
• Variable time delay 0,1 ... 20 s			
• Width:	35 mm		

### Variants

IL 9077.12/010:	3p4w, deenergised on trip with asymmetry detection
IL 9077.12/003:	3p3w, deenergised on trip with phase sequence detection
IP 9077.39:	3p4w, deenergised on trip
IP 9077.39/001:	3p3w, deenergised on trip
IP 9077.39/002:	3p3w, undervoltage output deenergised on trip, overvoltage output energised on trip

### Ordering example for variants

IL 9077	.12	/010	3 AC 230/400 V	50 / 60 Hz	0,1 ... 20 s	
						Time delay
						Nominal frequency
						Nominal voltage
						Variant
						Contacts
						Type

