

Diagram 1

Shows BH 5932.22, BD 5935.48 and a 3 contact solenoid locked gate switch.

BD 5935.48 is connected for dual channel input with cross fault monitoring of the E stop contacts and safety gate switch contacts.

The solenoid n/c contact is monitored via the S33–S34 terminals of BD 5935.48.

If contact welding occurs on the gate switch or solenoid contact the BD 5935.48 will inhibit restart of the motor.

Special Note

If it is required to drive external positive guided contactors via BH 5932, safety contacts 13-14, 23-24 may be used. The N/C auxiliary contacts on these contactors should be monitored in series with terminals X1-X2. If external monitoring is not required these terminals must be bridged.

Typical Schematic Diagram

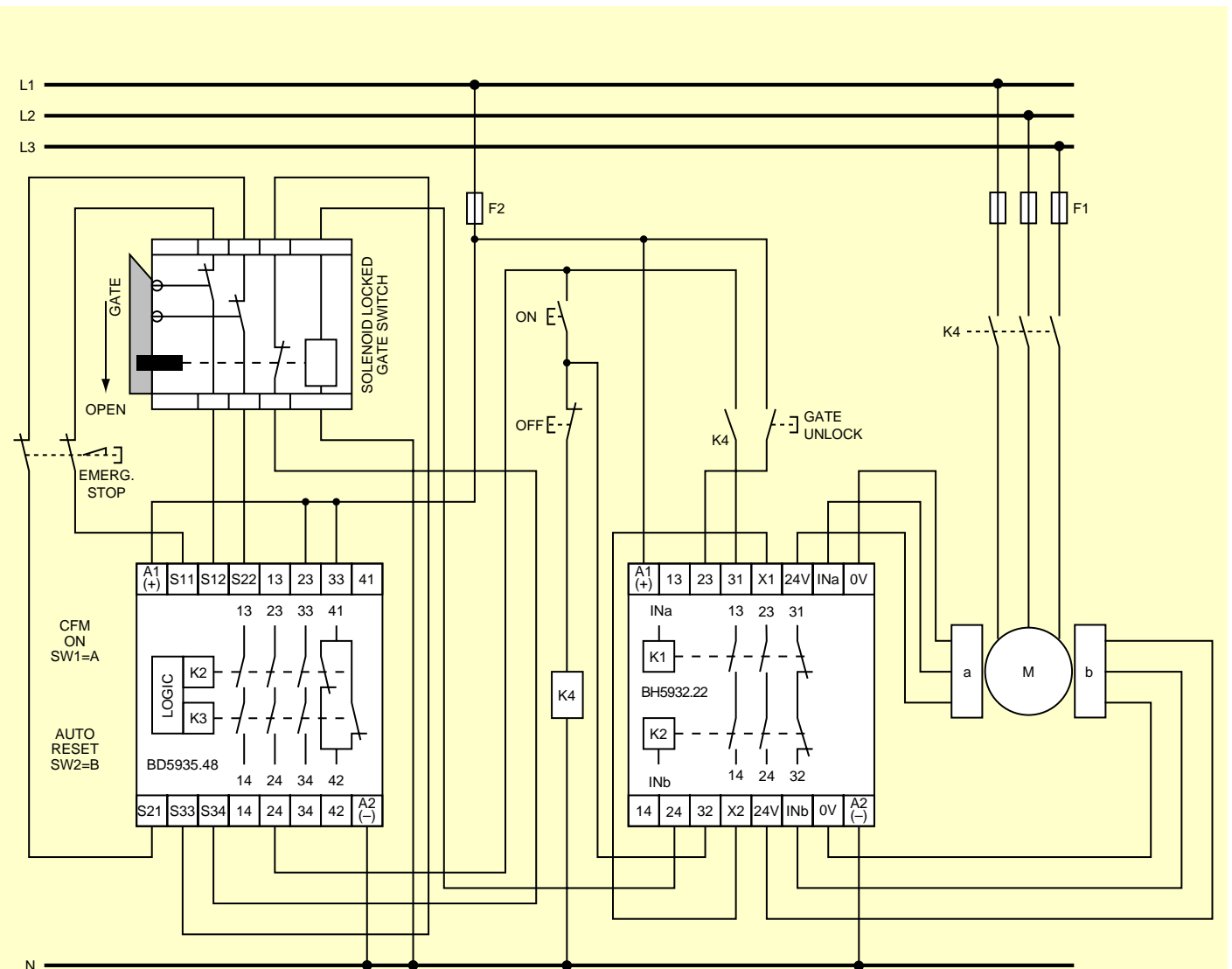

BH 5932.22, BD 5935.48 with cross fault monitoring, 3 contact gate switch

Diag 1

Diagram 2

Shows BH 5932.22, BD 5935.48 and a 2 contact solenoid locked gate switch.

BD 5935.48 is connected for dual channel input with cross fault monitoring of the Estop contacts and safety gate switch contacts.

If contact welding occurs on the gate switch contacts, the BD 5935.48 will inhibit restart of the motor.

Typical Schematic Diagram

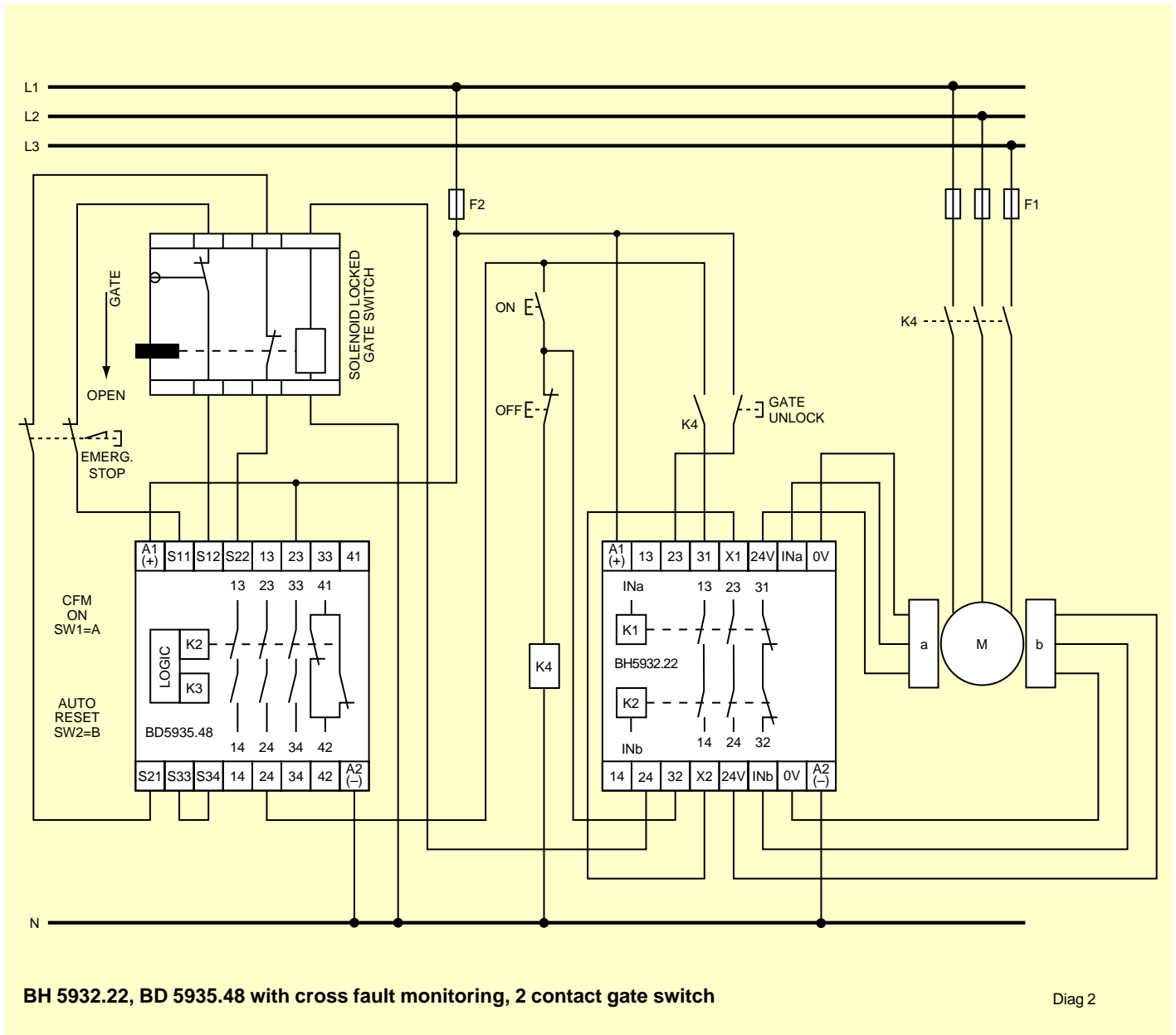

Type BH 5932.22 safemaster

Additional Information

BH 5932 may be used for both standstill and speed monitoring applications, all units have 2 sensing channels.

Variants

Four main variants are available:

1. Versions with fixed tripping value (standstill).
2. Versions with a common adjustment for both channels (standstill).
3. Versions with separate adjustment for both channels (overspeed).
4. Versions with one common adjustment for both channels and a fine tuning adjustment to synchronise both channels (overspeed).

Setting ranges

On adjustable units the total measuring range is split up into 4 sub ranges which can be selected by two DIP-switches per channel S1 and S2, these are accessed by removing the front cover of the relay. The two potentiometers are used to adjust the IPM value within the selected range.

Switch Settings

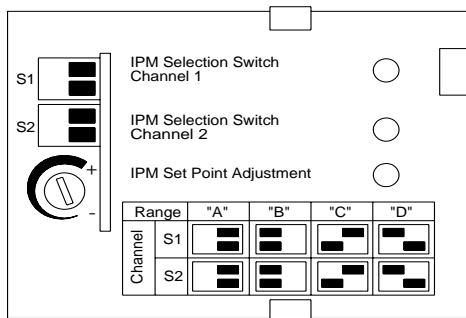

IPM range: A = 7-90 / B = 60-700 / C = 470-5500 / D = 1800-21000

BH5932.22 options, /001, /011, /101, /111

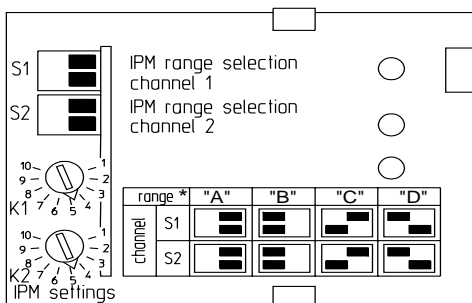

IPM range: A = 8-60 / B = 60-450 / C = 450-3600 / D = 1800-14000
or: A = 20-110 / B = 120-900 / C = 950-7000 / D = 3700-26000

BH5932.22 options, /002, /012, /102, /112

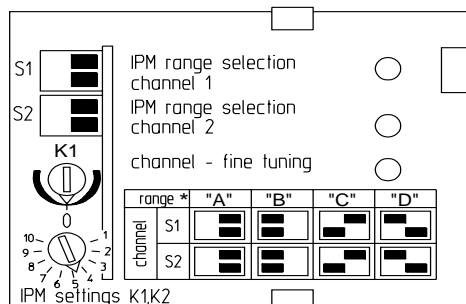

IPM range*: A = 5-40 / B = 35-340 / C = 300-2700 / D = 1200-10500
or: A = 10-80 / B = 80-650 / C = 600-5300 / D = 2400-20000

BH5932.22 options, /003, /013, /103, /113

Additional Information

Adjustment of setting range

The number of pulses per minute [IPM] to be adjusted can be calculated using the following formula:

$$\text{RPM} \times \text{the number of sensing points} = \text{IPM}$$

e.g. 7.5 Rpm x 2 sensing points = **15 IPM**

Operation as a standstill monitor

Both channels must be adjusted so that they switch simultaneously or as near as possible. The maximum time between standstill detection and the switching of the output relays is dependant upon the set IPM value. This delay can be calculated as follows:

$$\frac{60 \text{ s}}{\text{adjusted IPM-value}} + 2.5 \text{ s} = t_{vs}$$

t_{vs} = the contact operation delay after standstill detection

e.g. at a setting of 15 IPM

$$\frac{60 \text{ s}}{15} + 2.5 \text{ s} = 6.5 \text{ s}$$

NB: The greater the number of sensing points the shorter the delay before standstill is detected. It is recommended that the IPM is set in the middle of the chosen range if possible.

Operation as an overspeed monitor

On overspeed monitoring it is necessary to adjust both channels precisely for simultaneous switching. If the two channels do not switch at the same point, the disconnection of the drive is only made via the channel with the lowest setting. The speed may then drop immediately so that the other channel does not detect overspeed and remains switched on. A system restart is then disabled and the relay will not switch on again. A restart will then only be possible by disconnecting the power supply. To achieve the best setting resolution, the IPM setting value should be in the middle part of the setting range. The adjustment of simultaneous switching is made easier on units with the one fine tuning potentiometer, i.e. /--3 variants.

Proximity sensors

For safe operation the proximity sensors should be installed on a vibration free mounting. The position of the sensors should be chosen in a way that both sensors are operated simultaneously, but care must be taken so that sensors do not interfere with each other. On standard units the connection of the sensors to the supply is monitored, so if there is an interruption in the sensor supply the corresponding output relay cannot be switched on, or if it is already on, it will switch off immediately. To achieve fault free operation, the sensor must draw at least 3 mA in the OFF state. If sensors with lower consumption are used only versions of BH5932 without sensor detection can be used. If this is the case, according to EN 954-1 the sensors must be checked for correct function within reasonable time intervals.

Feedback circuit, reset, LEDs and timing

The reset circuit X1 - X2 must be closed before connecting the power supply. The unit is ready for operation, typically 1.5 sec after the supply is connected.

The LEDs channel 1 and channel 2 are on when the corresponding relay is energised. The output contacts of the relays will only be activated if both input channels reach the enabled condition within a time span of 2 sec approx. If the response value is not reached on both channels within this time, e.g. because of a defective sensor or because the sensors do not simultaneously switch, the output contacts will not be energised.

Dimensions

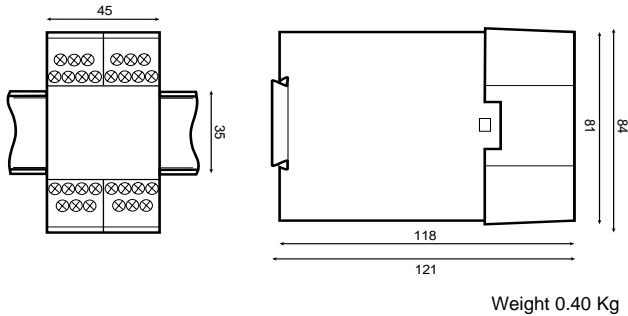

Specifications

Nominal Voltage Vn	24Vac/dc, 110V, 230Vac (to be specified)
Burden	4VA ac/2.5 W dc
Voltage Tolerance	0.8... 1.1 Vac 0.9... 1.1 Vdc
Frequency	45... 65 Hz.
Contacts	2 N/O, 1 N/C
Max. Switching Capacity	8A ac (Cos Phi 1–0.7) 8A dc see page **
Continuous Current Rating	see page **
Contact Life, Mechanical	30 x 10 ⁶ operations
Contact Life, Electrical	see page **
Derated Capacity (for heavy inductive loads)	AC15, 4A, 250V DC13, 4A, 24V dc
Min Switching Voltage & Current	10V, 15mA, ac/dc
Max Switching Voltage	250V ac, 250V dc
Max Switching Power	2000 VA (AC1) 192W dc
Startup ResetTime	1.5 sec
Hysteresis	6%
Sensor output voltage	24V dc nom
Sensor Minimum current	3 mA min
Sensor Maximum current	25 mA max per channel
Reaction time	t _v +30 ms
Max Operating Frequency	30000 IPM
Min Pulse Width	1ms (m/s ratio 1/1) = 30000 IPM
Operating Temperature	-25°C...+60°C at 90% RH
Protection Class	Case IP40, Terminals IP20
Test Voltage Input/Output	4KV VDE 0110 – 1 – 2
Shock Loading	Amplitude 0.35mm Frequency 10 – 55 Hz. (5g @ 50 Hz.)
Enclosure Material	Thermoplastic VO Rating UL94
Terminations	1 x 4mm ² solid 2 x 2.5mm ² solid 1 x 2.5mm ² stranded ferruled

Versions

Devices with fixed standstill setting

BH 5932/100, BH 5932/110: 15 / 30 / 60 / 120 IPM, fixed others on request
(the output contacts close, when the speed is under the set IPM values)
Operate delay at standstill: see formula on sheet 4

Information Required With Order

• Model type • IPM • Auxiliary Supply

Example: Speed Monitor Type BH 5932.22/103

5 - 1050 IPM, Auxiliary Supply 24V dc

Options

BH 5932 .22 /	AC 230 V 50/60 Hz 60IPM	
		Setting value
		Nominal frequency
		Nominal Voltage
		Variants, if required
		0 = Fixed setting value
		1 = Adjustable setting value channel 1 and 2 together
		2 = Adjustable setting value channel 1 and 2 with separate adjustments
		3 = Adjustable setting value channel 1 and 2 together with fine tuning to synchronise both channels
		0 = NPN-input
		1 = PNP-input
		0 = No sensor (I) detection
		1 = With sensor (I) detection
		Contacts Type

Versions continued

Devices with adjustable standstill setting (one pot)

BH 5932/101, BH 5932/111
Range 7 ... 21000 IPM: Adjustable in 4 subranges
7... 90, 60 ... 700, 470 ... 5500
1800 ... 21000 IPM
(the output contacts close, when the speed is under the set IPM values)
Operate delay at standstill: see formula on sheet 4

Devices with separate adjustable channels

BH 5932/102, BH 5932/112
Range 8 ... 14000 IPM: Adjustable in 4 subranges
8 ... 60, 60 ... 450, 450 ... 3600,
1800 ... 14000 IPM

or
Range 20 ... 26000 IPM: Adjustable in 4 subranges
20 ... 110, 120 ... 900, 950 ... 7000,
3700 ... 26000 IPM

Operate delay at standstill: see formula on sheet 4
Release delay on overspeed Range 8 ... 14000: t_{off} = typ. 700 ms
Range 20 ... 26000: t_{off} = typ. 350 ms

Devices with fine tuning of simultaneity

BH 5932/103, BH 5932/113
Range 5 ... 10500 IPM: Adjustable in 4 subranges
5 ... 40, 35 ... 340, 300 ... 2700,
1200 ... 10500 IPM

or
Range 10 ... 20000 IPM: Adjustable in 4 subranges
10 ... 80, 80 ... 650, 600 ... 5300,
2400 ... 20000 IPM

Operate delay at standstill: see formula on sheet 4
Release delay on overspeed Range 5 ... 10500: t_{off} = typ. 700 ms
Range 10 ... 20000: t_{off} = typ. 350 ms